

# KW-FFT2A[AC], KW-FFT2B[Battery]

TANDEM FILLET WELDER, FLOOR TRAVEL, DUAL TORCH, STITCH & CONTINUOUS

## APPEARANCE

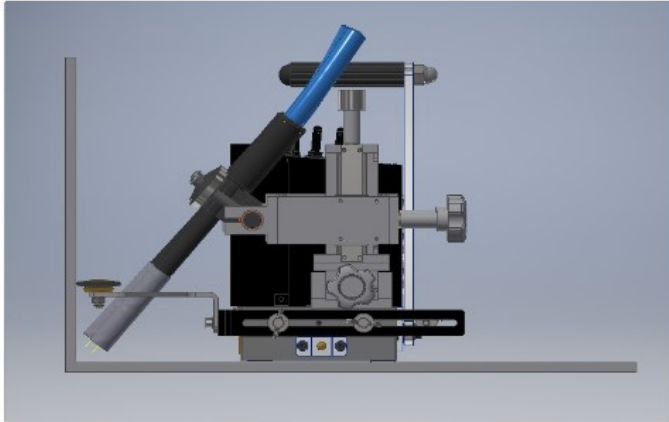

## FEATURES

- Dual torch, floor driving for Tandem fillet welding
- Stitch & continuous welding
- X-Y slider helps setting torch widely
- Both mechanized & manual torches useful.
- Max pulling power of magnet 20kgf and travels Max. 30°climbable.
- Limit switches stop the travel automatically.
- Crate filling time at the beginning and ending of the welding can be controlled for 0~3 seconds.
- Travel speed in cm/min or inch/min programmable.
- Battery power, 18Vdc 6.0Ah lithium-ion, 10Hrs use

## TANDEM FILLET WELDING

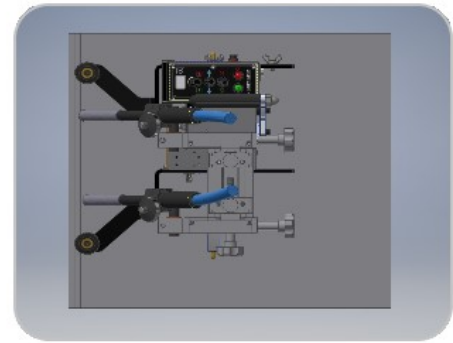
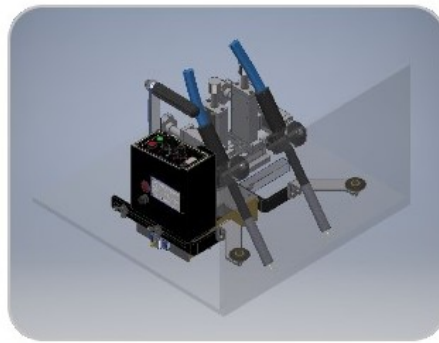
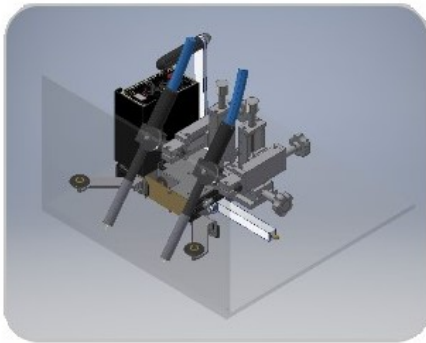

MAJOR PARTS	DESCRIPTIONS	SPECIFICATIONS
General	Size in mm(WHL), Weight	Carriage: 380 x 300 x 330, 11.0Kg Packing: 360 x 360 x 380, 14.0kg
	Input source	AC 100-240V, 50-60Hz, 1Phase Lithium-ion Battery 18Vdc 6.0Ah 10Hrs use
	Power unit	24Vdc, 10W, 5,000rpm
Traveling Unit	Reducer	1:624
	Speed	0~860mm/min
	Power transmission	4 wheels chain driven
	Magnet location	Bottom on the carriage
	X-Y-Z slide	X-slide stroke
	Y-slide stroke	0~50mm
	Z-slide stroke	0~50mm
	Torch adjustable angle	0-90°